

www.rotofluidpumps.com
ROTARY TWIN GEAR PUMPS

Series: FTNX / FTBX



Rotary Gear Pumps
SINCE : 1993

Perfect Solution

for transfer of Oil, Viscous Liquid
& Petroleum Products

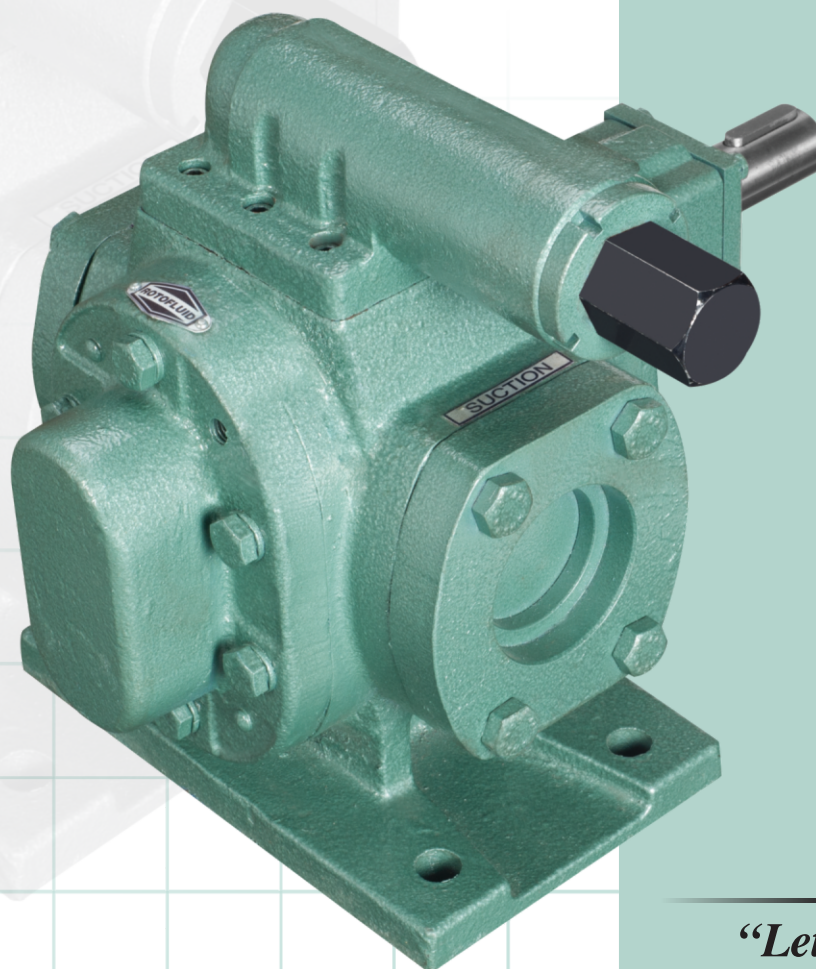

*“Let Our
Quality Speak
For Itself”*



Fluid Tech Systems

Ahmedabad - 382 430. (Guj.) INDIA

ADVANCE TECHNOLOGY FOR PUMPING VISCOUS LIQUID

“**ROTOFLUID**” Pumps having established in the year 1993 has become an integral part of most industries. Based in Ahmedabad, India, we are involved in manufacturing, quality control, selling, installing and servicing of Rotary Gear Pumps.

Fluid Tech Systems offer “**ROTOFLUID**” brand gear pump Model “FTNX/FTBX” which is heavy duty flange and foot mounting type positive displacement rotary gear pump. Model “FTNX/FTBX” is modified version of Model “FTRN/FTRB” to achieve high pressure. These pumps having doubled helical finished gears and hardened & ground shafts. Due to double helical gear it prevent axial load and side thrust which help to increase life and performance of pump.

In these pumps size ½" to 2 ½" are provided with thread at end of suction & delivery and they are available with foot or flange mounting, But in size 3" to 4" are provided with flange at the end of suction & delivery and they are available with foot mounting only. These pumps flange are as per standard AFA/ANSI - 300 class. These pumps can be operated up to pressure of 20 kg/cm² with 5.0 LPM to 900 LPM flow capacity. These pumps are suitable for liquid up to viscosity of 1, 00,000 SSU and maximum temperature up to 200°C.

APPLICATION

- Power plant.
- Steel plant.
- Cement plant.
- Bitumen plant.
- Petroleum industries.
- Refineries.
- Pumping station.
- All kind of liquid loading and unloading.

FEATURES

- High pressure pump offered to 50 Bar.
- Heavy duty gear pump design for continuous application.
- Modification tooth profile enhances the tool life.
- Floating gear design ensures uniform load distribution.
- Heavy duty gear pump double helical design prevent axial load and side thrust.
- Shorter bearing span reduces bending effect.
- Low leakage path by design improve volumetric efficiency.

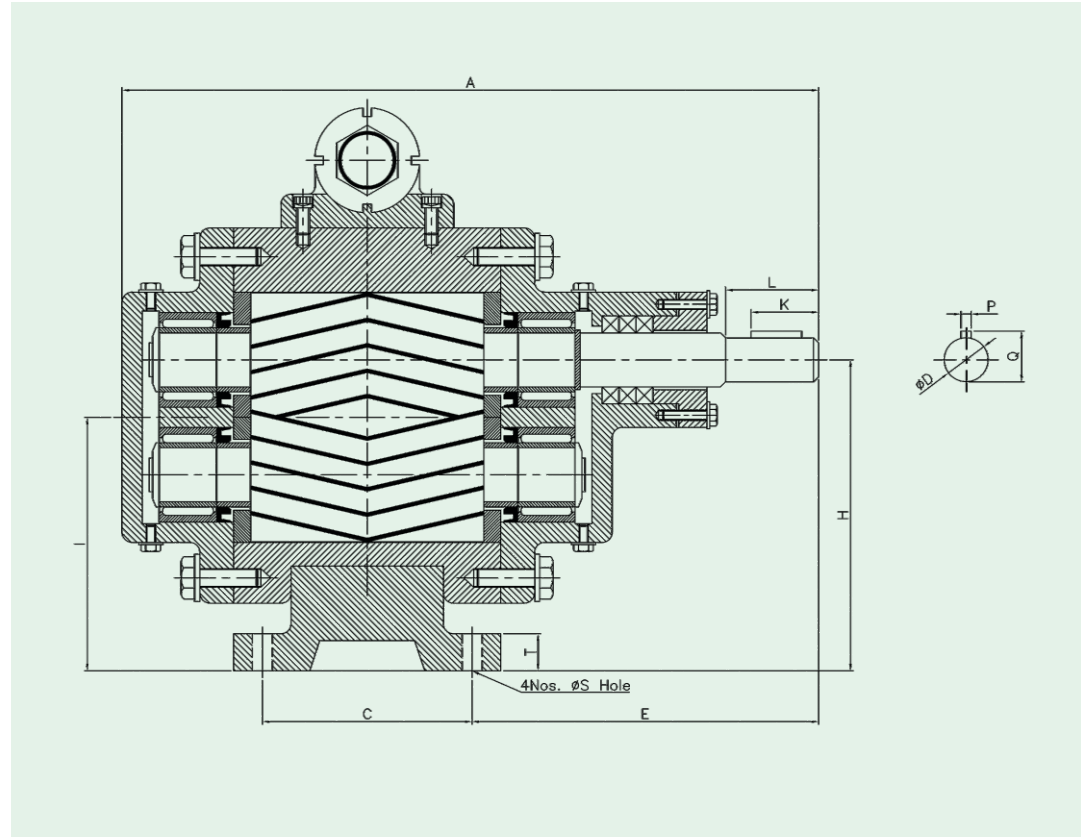

MATERIAL OF CONSTRUCTION

Model	Material For FTNX	Material For FTBX
Pump Body	CI/CS/SS	CI/CS/SS
Front Cover	CI/CS/SS	CI/CS/SS
Back Cover	CI/CS/SS	CI/CS/SS
Gland Cover	CI/CS/SS	CI/CS/SS
Rotor/Stator Shaft	EN-19/SS	EN-19/SS
Gear	EN-24/SS	EN-24/SS
Needle/Bush Bearing	INA/IKO [Japan]	Non- Ferrous
Wear Plate	Bronze	Bronze
Sealing	"GFO" Pack Teflon/Mech. Seal	"GFO" Pack Teflon/Mech. Seal
R.V. Housing	Mild Steel/SS	Mild Steel/SS
R.V. Piston	EN – 8/SS	EN – 8/SS
R.V. Spring	Spring Steel	Spring Steel
R.V. AD. Screw	EN-8	EN-8
Key	EN-8	EN-8
Hex – Bolt	Mild Steel	Mild Steel

AVAILABLE SIZE & CAPACITY

SIZE & MODEL	1440 RPM CAPACITY			PUMP GD 2 IN KGM2	ELE. MOTOR HP	FR. SIZE
	LPM	US GPM	M ³ /hr			
½" S 050 M L	05.00	01.32	0.30	0.0001	0.50	71 M
	08.33	02.21	0.50	0.0002	1.00	80 M
	16.66	04.42	1.00	0.0003	1.50	90 S
1" S 100 M L	25.00	06.60	1.50	0.0005	1.00	80 M
	33.32	08.80	2.00	0.0007	2.00	90 L
	41.65	11.00	2.50	0.0008	3.00	100 L
1.¼" S 125 M L	50.00	13.25	3.00	0.0005	2.00	90 L
	60.00	16.66	3.60	0.0006	3.00	100 L
	83.00	22.00	5.00	0.0008	5.00	112 M
1.½" S 150 M L	100.00	26.50	6.00	0.0045	3.00	100 L
	125.00	33.00	7.50	0.0057	5.00	112 M
	150.00	39.75	9.00	0.0068	7.50	132 S
2" S 200 M L	166.60	44.16	10.00	0.0068	5.00	112 M
	200.00	53.00	12.00	0.0081	10.00	132 M
	250.00	66.25	15.00	0.0100	15.00	160 M
2.½" S 250 M L	300.00	79.50	18.00	0.0160	7.50	132 S
	333.00	88.33	20.00	0.0174	15.00	160 L
	350.00	92.75	21.00	0.0185	20.00	160 L
3" S 300 M L	400.00	106.00	24.00	0.0361	25.00	180 M
	450.00	119.00	27.00	0.0469	30.00	180 L
	600.00	159.00	36.00	0.0560	35.00	200 L
4" S 400 M L	700.00	185.50	42.00	0.0750	40.00	200 L
	800.00	212.00	48.00	0.0870	50.00	225 S
	900.00	238.50	54.00	0.0980	60.00	225 M
5" S 500 M L	1000.00	265.00	60.00	0.1680	60.00	225 M
	1200.00	318.00	72.00	0.2800	75.00	280 S
	1400.00	371.00	84.00	0.2410	100.00	250 M
6" S 600 M L	1666.00	441.50	100.00	0.3245	75.00	250 M
	1915.00	508.00	115.00	0.3683	100.00	280 S
	2082.00	552.00	125.00	0.3947	120.00	280 M

ROTARY TWIN - GEAR PUMP TYPE FTNX / FTBX



Rotary Gear Pumps
SINCE : 1993

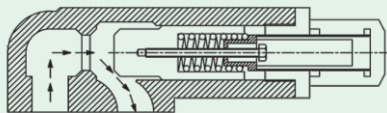
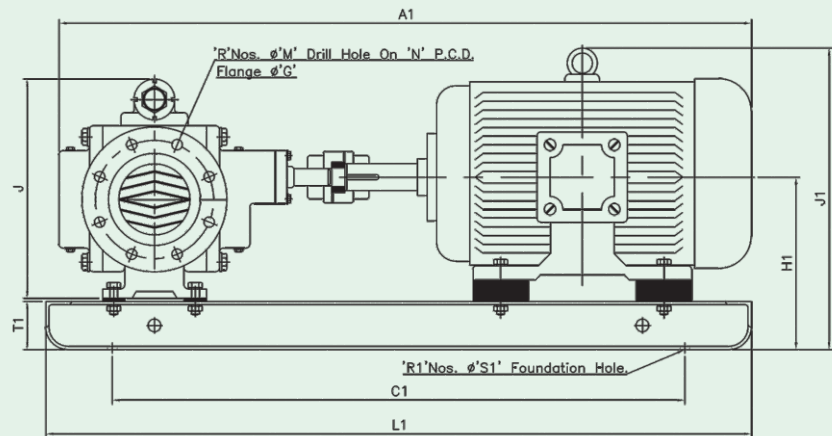
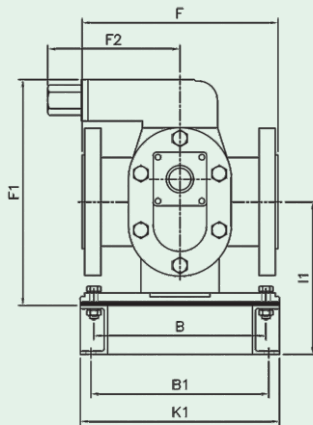

PRESSURE RELIEF VALVE

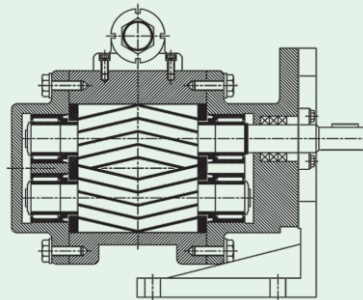

L - BRACKET CONSTRUCTION

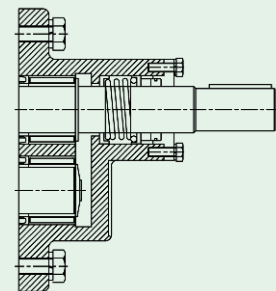

MECH. SEAK IN STUFFING BOX

DIMENSIONS

WEIGHT

OVERALL														MOUNTING					SHAFT			FLANGE		BP-COU PUMP IN KG.							
A1	J	A	J1	L1	K1	F1	F2	B	C	S	S1	E	F	H	I	H1	T	T1	C1	B1	I1	D	R		K	L	P	Q	M	N	G
455	139	235	425	140	143	-	119	8.5	58	71	115	15	370	112	104	11.5	22	04	M8	Sq 65	7.00										
505	--	251	450	150	153	112	-	-	-	-	124	-	405	112	113	-	-	-	-	-	6.00										
522	206	225	475	180	162	-	40	15	100	60	134	40	430	140	123	04	25	13	66.6	04	7.50										
520	151	251	500	170	155	-	125	8.5	69	80	124	15	445	135	108	15	25	05	M8	Sq 70	10.15										
560	--	225	525	180	165	112	-	-	-	-	134	-	480	140	118	-	-	-	-	-	11.00										
599	219	279	550	200	174	-	45	15	120	64	144	40	505	160	128	04	30	17	73	04	13.00										
591	185	235	550	180	189	-	155	10	81	90	144	15	485	140	124	21	30	06	M10	Sq 80	12.00										
630	--	289	600	200	195	141	-	-	-	-	154	-	545	160	134	-	-	-	-	-	14.50										
658	250	323	600	230	211	-	50	15	135	70	166	50	545	190	146	04	40	23.5	85	04	15.50										
673	205	289	625	200	207	-	170	12	95	100	154	20	570	160	132	24	40	08	M12	Sq 100	15.00										
700	--	321	650	230	220	153	-	-	-	-	166	-	595	190	144	-	-	-	-	-	24.00										
764	293	362	700	250	241	-	55	15	145	78	186	50	645	216	164	04	50	27	106	04	18.75										
746	234	338	700	230	238	-	200	12	94	112	181	20	630	190	155	27	40	08	M12	Sq 120	18.00										
850	--	377	825	250	258	173	-	-	-	-	205	-	755	216	175	-	-	-	-	-	35.00										
950	339	435	900	285	286	-	70	19	165	86	229	65	830	230	203	04	55	30	127	04	21.00										
850	261	387	800	260	266	-	225	15	104	132	211	25	550	200	182	32	50	10	M14	Sq 135	19.00										
990	--	445	900	315	294	173	-	-	-	-	239	-	650	254	210	-	-	-	-	-	55.00										
1030	375	445	950	315	294	-	80	19	190	103	239	75	700	254	210	04	60	35	149	04	23.00										
1165	338	568	1150	330	342	-	180	19	244	180	284	25	850	279	250	37	55	10	22	210	33.00										
1165	--	568	1150	330	342	205	-	-	-	-	284	-	850	279	250	-	-	-	-	-	73.00										
1235	436	616	1200	355	362	-	90	19	280	146	304	100	900	318	270	04	65	40	168	08	37.00										
1285	375	616	1300	370	379	-	180	19	258	200	304	28	900	318	264	47	70	14	22	254	52.00										
1330	--	666	1400	406	404	230	-	-	-	-	329	-	900	356	289	-	-	-	-	-	92.00										
1360	487	666	1400	406	404	-	130	22	300	160	329	100	900	356	289	04	80	50.5	200	08	58.00										
1405	420	691	1450	430	424	-	200	22	271	225	354	28	1050	356	308	52	75	16	22	279	52.00										
1495	--	794	1550	470	449	230	-	-	-	-	379	-	1050	406	333	-	-	-	-	-	142.0										
1590	533	854	1600	520	479	-	150	22	340	179	409	150	1150	457	363	04	85	56	235	08	76.00										
1510	467	819	1650	470	471	-	215	22	293	250	404	28	1150	406	354	57	80	16	22	317	78.00										
1610	--	879	1700	520	501	245	-	-	-	-	434	-	1150	457	384	-	-	-	-	-	173.00										
1610	550	879	1700	520	501	-	170	22	345	200	434	150	1150	457	384	04	95	61	270	12	85.00										

PUMP CHARACTERISTIC

Gear Pump is versatile rotary positive displacement pump with positive Pressure characteristic. The capacity of the pump is directly proportional to the speed but remain constant against pressure the different between theoretical and delivery capacity is the slip of the pump which depends on speed, Viscosity of liquid working clearance, Differential pressure & workman Ship. The pumps are capable of handling any kind of viscosity, the slip reduce with viscosity but the viscous power increase due to the resistance of the fluid to shear. The pump has a self priming capability however some net inlet pressure available must always equal or positive suction head NPSH is always required to avoid cavitations depending upon the viscosity of the liquid to be pumped & the pump speed

PUMP HORSEPOWER AND EFFICIENCY

The brake horsepower required to drive a rotary gear pump is the sum of the theoretical horsepower and the internal power losses. The theoretical liquid horsepower is the actual work done in moving the liquid from the inlet pressure condition to the outlet at discharge pressure. This work is done well on all the fluid of theoretical capacity, not just delivered capacity, as slip does not exist until a pressure differential offer.

Note that, theoretical liquid horsepower is independent of viscosity and is concerned only with the physical dimension of the pumping elements, the rotating speed and the differential pressure.

THE INTERNAL POWER LOSSES

The Internal Power Losses are made up of two types: mechanical and viscous. The mechanical losses include all power necessary to overcome the mechanical friction drag of all the moving parts within the pump, including bearings, gears, mechanical seal etc. The viscous losses include all the power lost from the fluid viscous drag effects against all the parts within the pump as well as from the shearing action of the fluid itself.

It is probable that the mechanical loss is the major component when operating at low viscosities and high speeds while the viscous loss is the larger at high viscosity and slow speed conditions.

PUMP SPEED

Model "FTBX/FTNX" are recommended to run at rated speed up to 500 CST viscosity, For viscosity between 500 to 1250 CST pump speed should be reduce up to 60% of rated speed, For Viscosity between 1250 to 2500 CST speed should be reduce up to 30% of rated speed.

PUMP SELECTION

The self lubricated needle roller bearing type Model FTNX used in clean liquid having sufficient lubricating property such as clean lube oil, Gear oil, Animal oil, Fish oil, Hydraulic oil, Vegetable oil. However self lubricated bush bearing type model FTBX used in viscous liquids and semi viscous liquids. Model "FTBX" is a bush bearing type pump which can be used for viscous liquid having sufficient lubricating value for intermittent duty; however for continuous duty, pump have needle roller bearing in Model "FTNX" and it will be selected for liquid having low viscosity, power lubricating values.

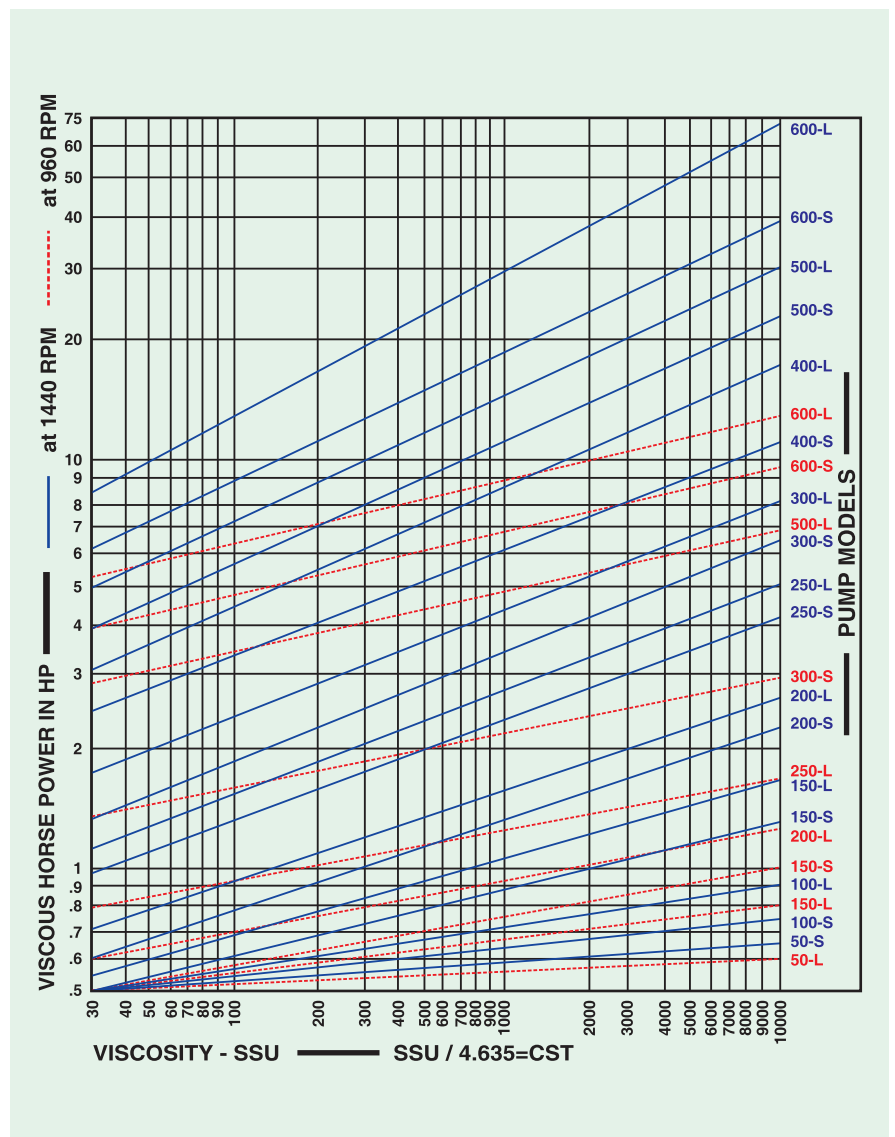

Mfgd. by :



Fluid Tech Systems

73, Tribhuvan Industrial Estate, Opp. Road No. 11,
Kathwada GIDC, Ahmedabad- 382430. Guj. INDIA.

E-mail : info@rotofluidpumps.com * Web : www.rotofluidpumps.com



Distributor :